

# 面对车载市场的产品介绍

美しい電子部品を究めます

**ALPS**<sup>®</sup>

# 车载市场产品图示 (面向车厂, 一级, 二级供应商)

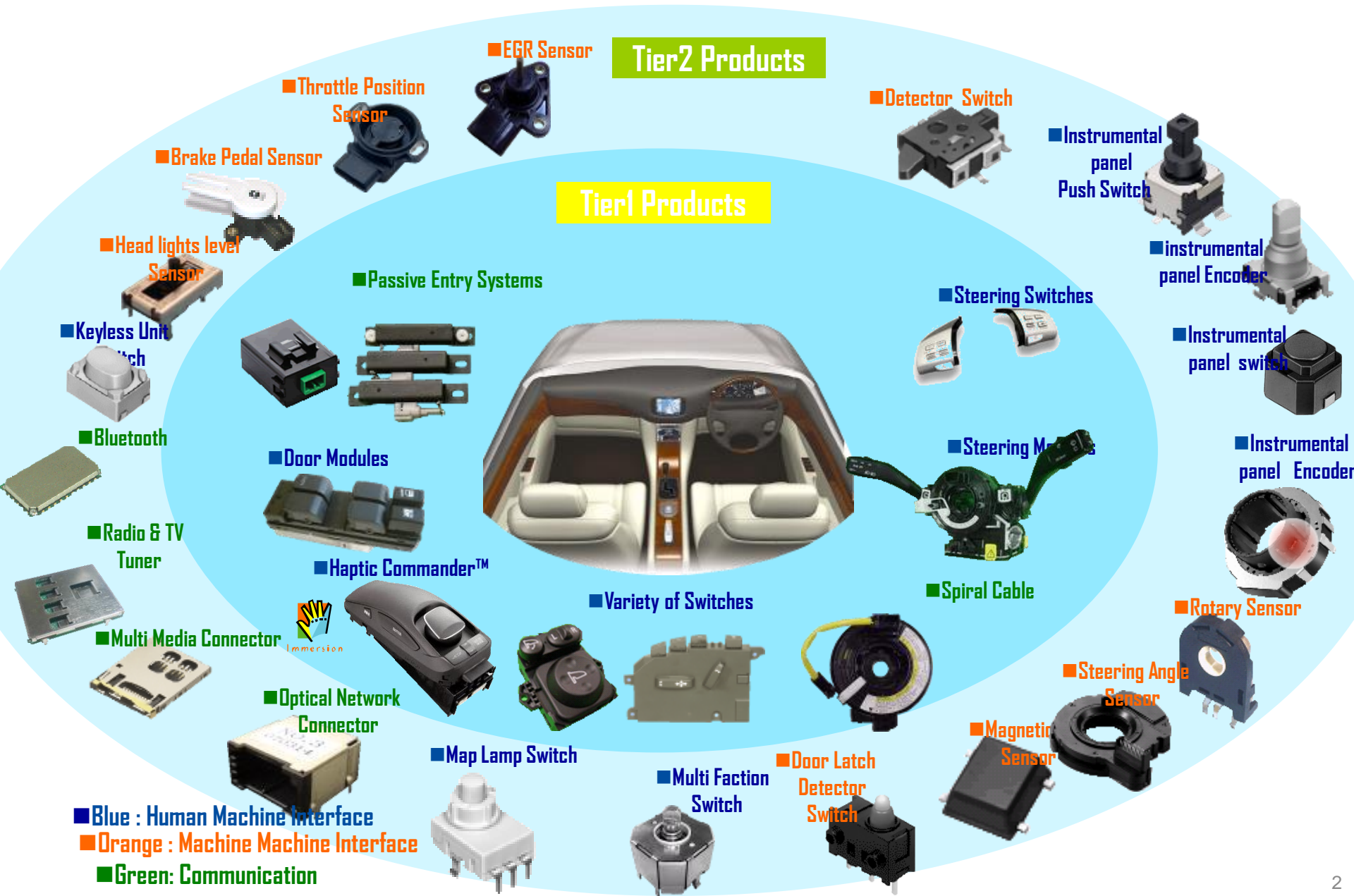

# 汽车内饰产品图示

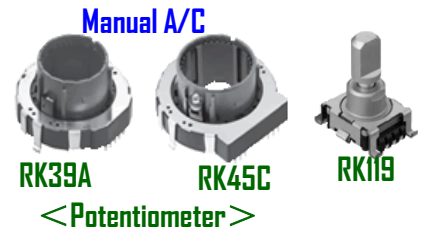
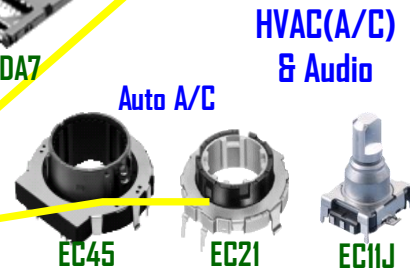
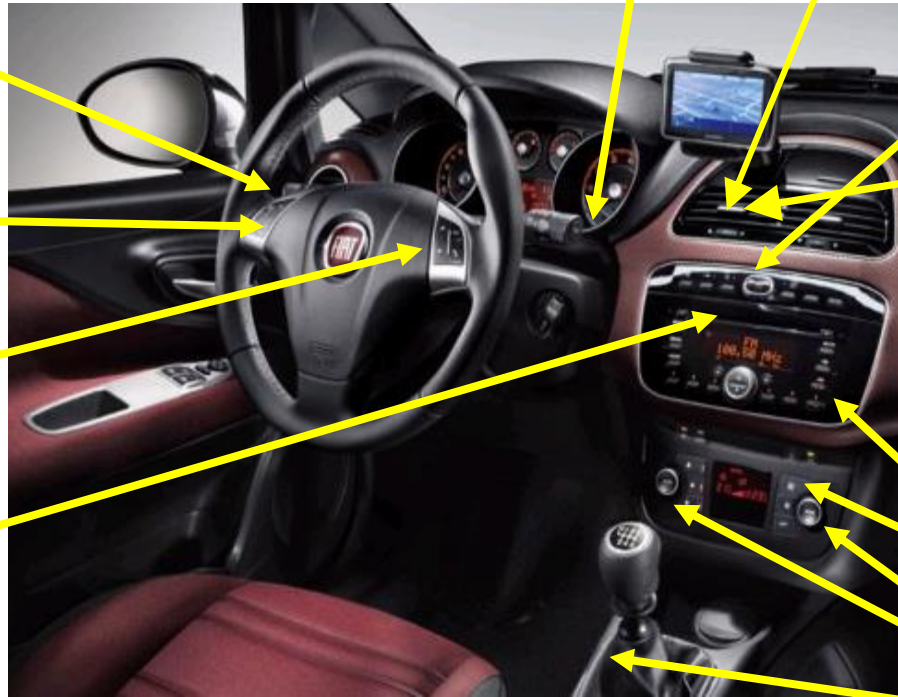
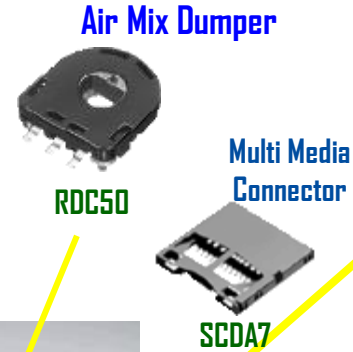

# TSW for Automotive

Audio/Navi  
HVAC / Steering

Over Head Console



Door Mirror Position



Long stroke: 1.0mm or more



SKPM

SKPR

Middle stroke: 0.3mm to less than 1.0 mm

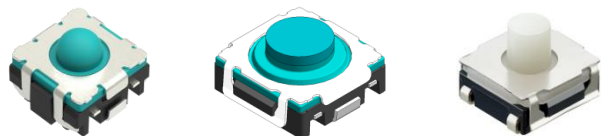

SKSU

SKST

SKRA

Short stroke: Less than 0.3mm



SKTH

SKSG

SKRP

SKQG

SKRB

RKE



Seat Position /  
Seat Heater Control

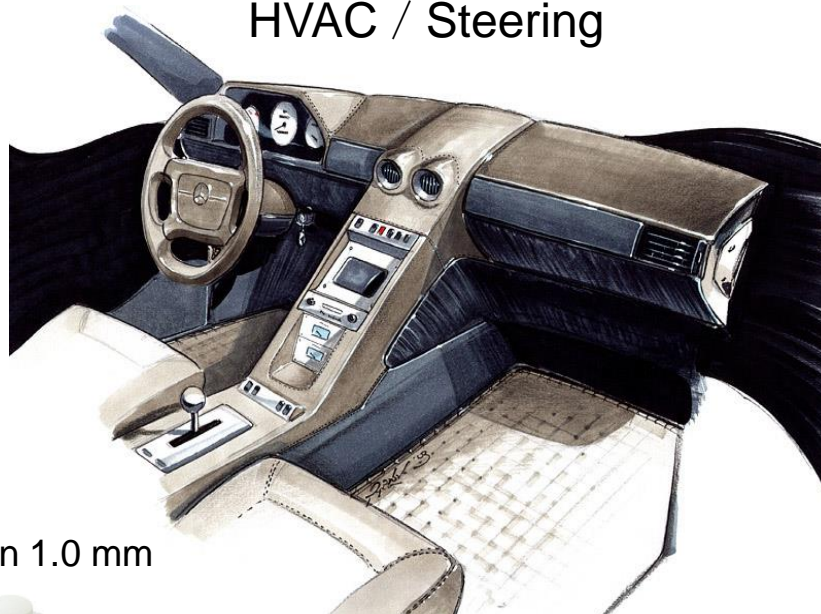

## Latch mechanics

Side door  
Key lock/unlock



Tale gate



Tale gate  
auto-closer



Slide door



Slide door  
Auto-closer



Hood Latch



Window  
Regulator



## Exterior

Door handle



Tail gate handle



Fuel tank lid



Convertible Top



Brake switch



EV Charger outlet



EV Charger



## Interior

Map lamp  
& Over head



Seatbelt buckle



HVAC DEF



Power Window



Airbag  
cut off



Ignition sw



Hazard SW



EPB



AT shifter



Overhead monitor



Steering Lock



Glove box  
LED lighting



Engine Starter



# Encoders and Potentiometers for Automotive

エンコーダ

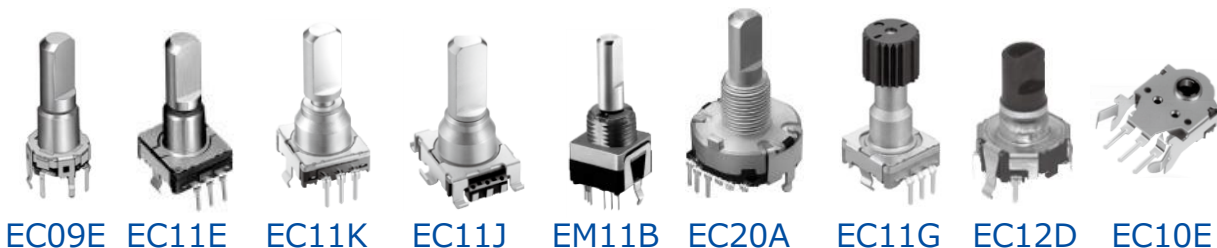

中空軸エンコーダ



オーディオ / HVAC / コントロールパネル  
/ ステアリング / メータ用操作デバイス

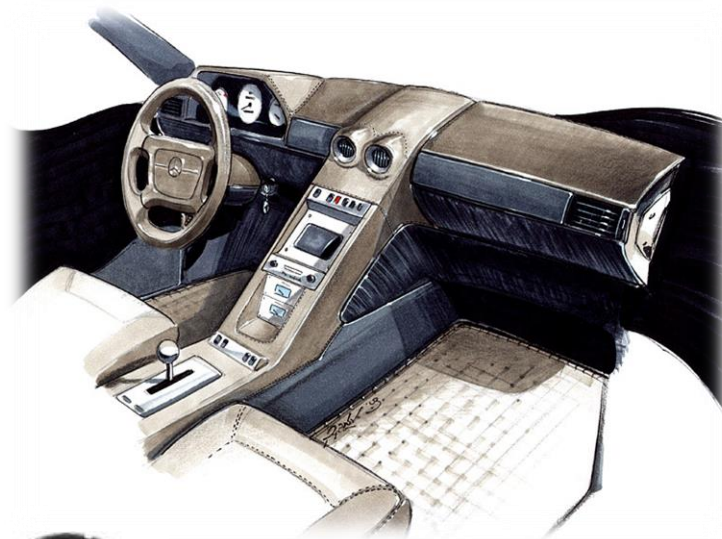

可変抵抗器



多機能操作デバイス



## HVAC

Mode detection

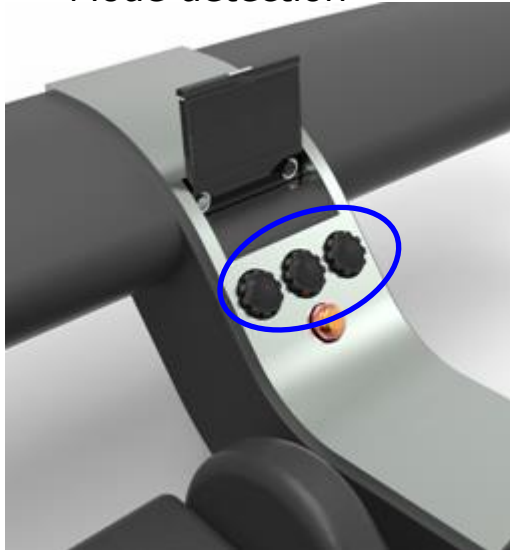

## Navi monitor

Open & close angle detection

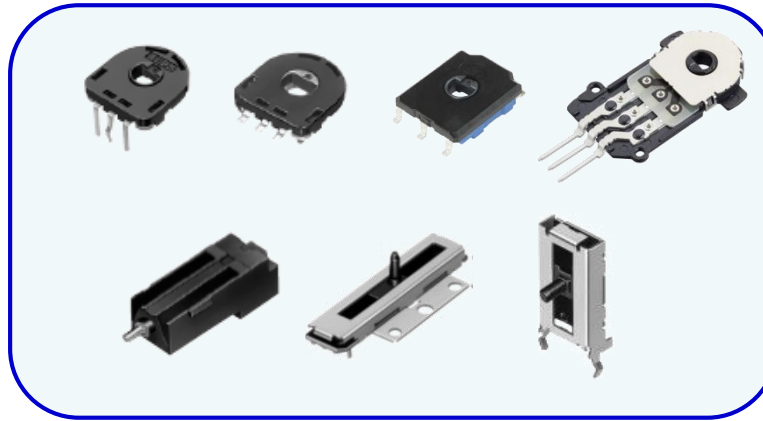
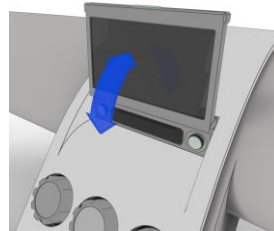

## Air conditioning unit

Angle Detection of the actuator output shaft

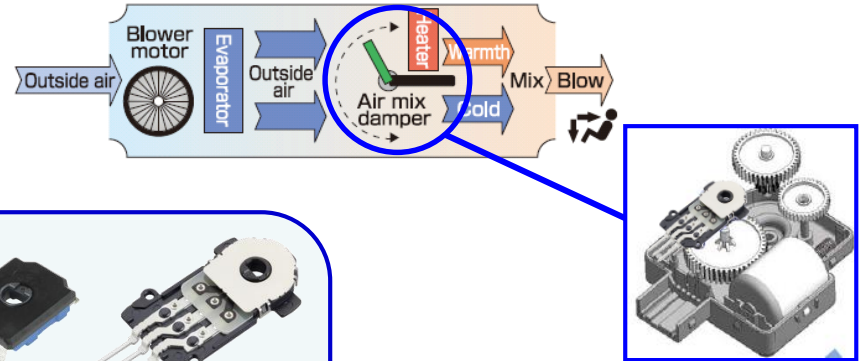

## Headlight

Light angle detection



## Door mirror

Mirror angle detection

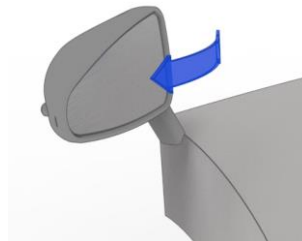

## Seat Recliner

Head restraint angle detection

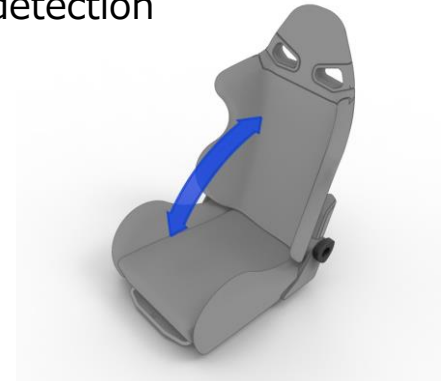

# Multi Control Devices for Automotive

For Car Navigation, Car Audio and Car Air Conditioner etc.





# 智能汽车系统



ITS  
ADAS / DSSS



Infotainment

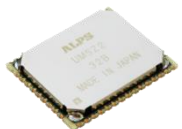

GNSS  
Module

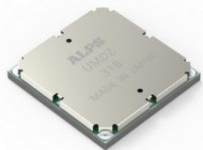

LTE  
Module

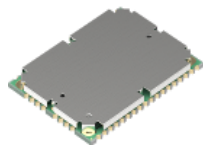

V2X  
Module

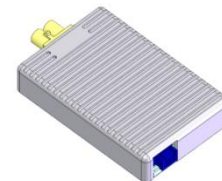

Remote  
Tuner

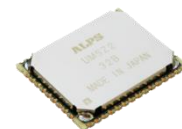

BT/W-LAN  
Module

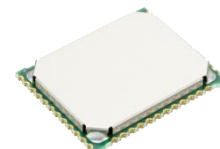

Bluetooth  
Module

Telematics

# V2X (Vehicle to X) 通信模块

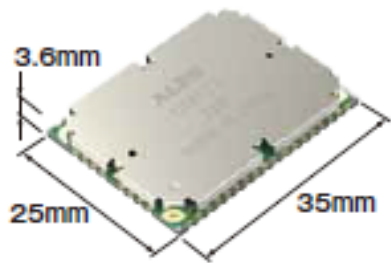

V2X system block diagram

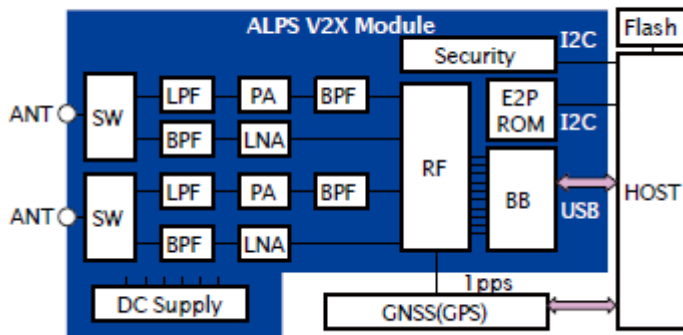

無線プロトコル	IEEE 802.11p	IEEE 802.11p	IEEE 802.11p
DSRCプロトコル	ETSIプロトコル ETSI EN 302 663	WAVEプロトコル IEEE 1609.x	ARIB T109
周波数	5.855-5.925GHz	5.850-5.925GHz	760MHz
周波数帯幅	10MHz	10MHz (Option 20MHz)	10MHz
スループット	3-27Mbps	3-27Mbps (6-54Mbps)	3-18Mbps
各国の状況	Euro-NCAP (※1)にV2X追加 を検討	米政府義務化に 向けて検討を 開始	2015年 国内サービス 開始予定

※1: European New Car Assessment Program;ヨーロッパで実施されている自動車衝突安全テスト

## 車車間・路車間

左折二輪車衝突防止支援システム

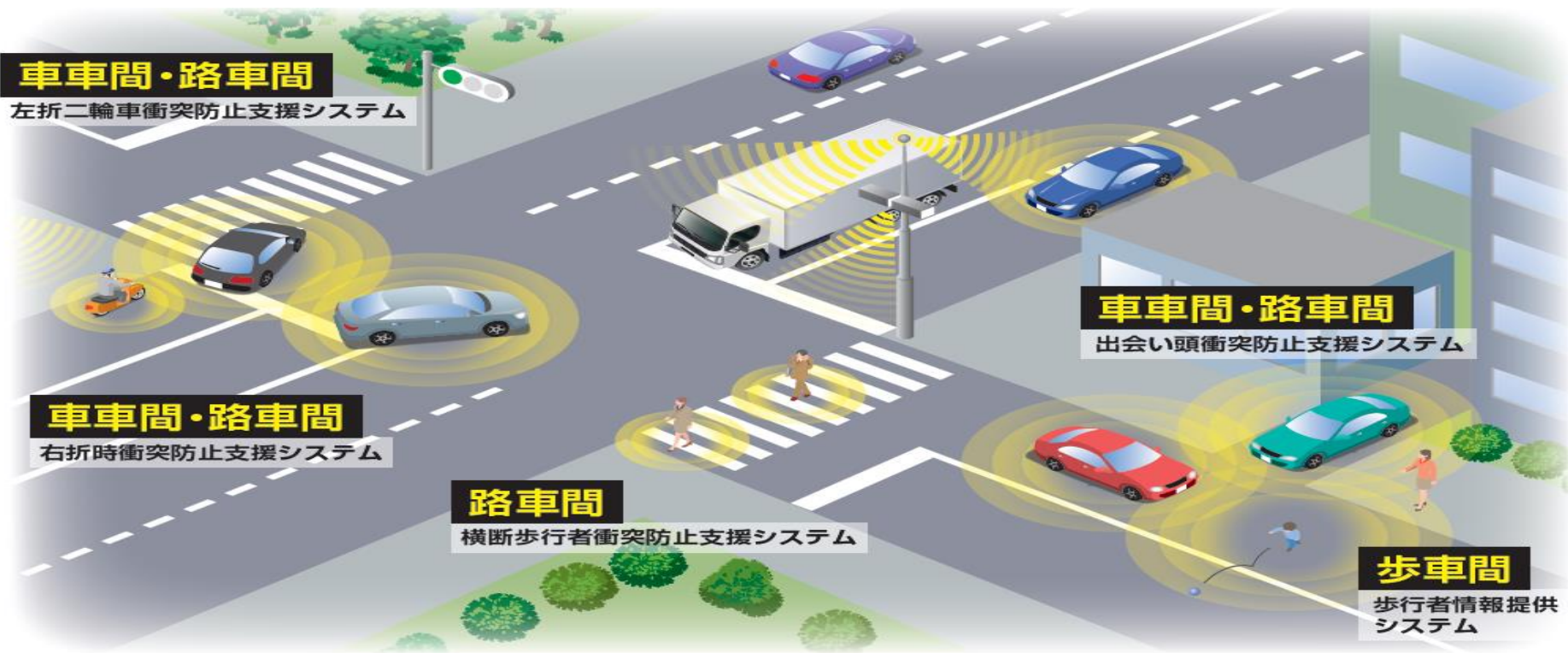

## 車車間・路車間

出会い頭衝突防止支援システム

## 車車間・路車間

右折時衝突防止支援システム

## 路車間

横断歩行者衝突防止支援システム

## 歩車間

歩行者情報提供システム